



Parktron
博辰科技

Automatic Gate

AGT213F

The AGT213F automatic gate is designed for vehicle access control. It can be widely used in places such as parking lots, toll gates, warehouses, railway crossings and commercial premises. The standard length of the gate arm is 3 meters with 3 seconds manufacture pre-defined opening time.

Functions and features:

- ① Manual release.
- ② Machine core adopting compression spring, effectively avoids accidents caused by spring breaking.
- ③ Die-casting aluminum alloy motor, precise operation and good at thermal radiation.
- ④ Motor with cooling fan to ensure overheat-protection.
- ⑤ Double safety limit switches (photo-electricity limit switch/motor memory sensor)
- ⑥ Reversing on obstacle.
- ⑦ Auto-closing.
- ⑧ Support infrared photocell for anti-bumping function (Optional).
- ⑨ Support external or internal vehicle loop detector (Optional).
- ⑩ Traffic light interface available.
- ⑪ Wired control (switch signal) / Remote control (418MHz).

Machine Core

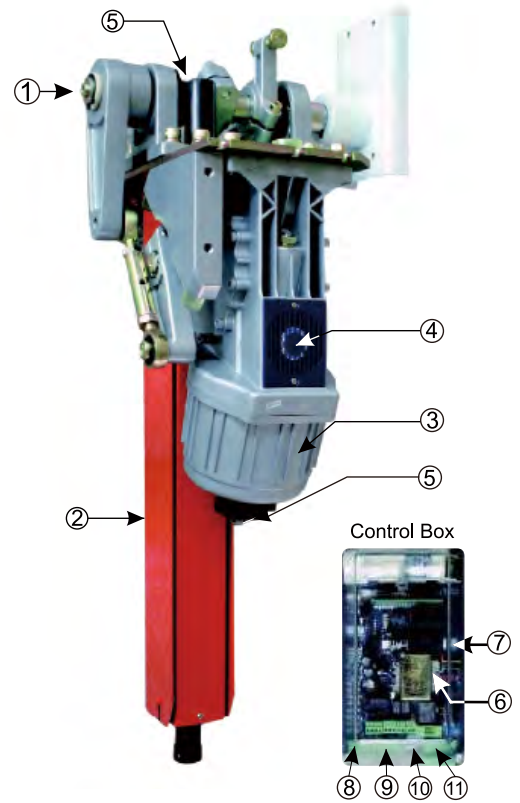

Technical Specification

Power Supply	AC110/220V± 10% , 0.8 /1.6A, 50/60Hz
Motor	220V / 120W Single phase
Working temperature	-40° ~ +55°C
Weight	60Kg
Gate arm length	3 M (Max. 4M)
Gate opening time	3 seconds
Dimensions (W x D x H)	35 x40 x107 cm

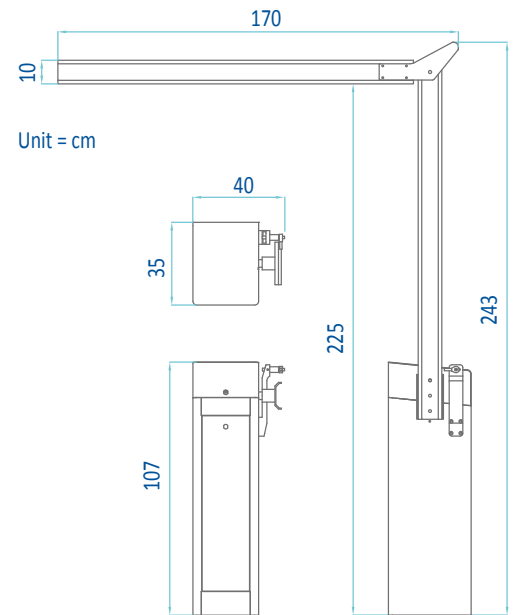

*specifications are subject to change without notice.

System and wiring diagram

